

Avoid presence of any body made of conductive material below the rotor's lower surface within 1 mm under the rotor and within the functional zone - to prevent parasitic capacitance

The functional zone is within the ring between radii 65 and 50 on both the stator and the rotor

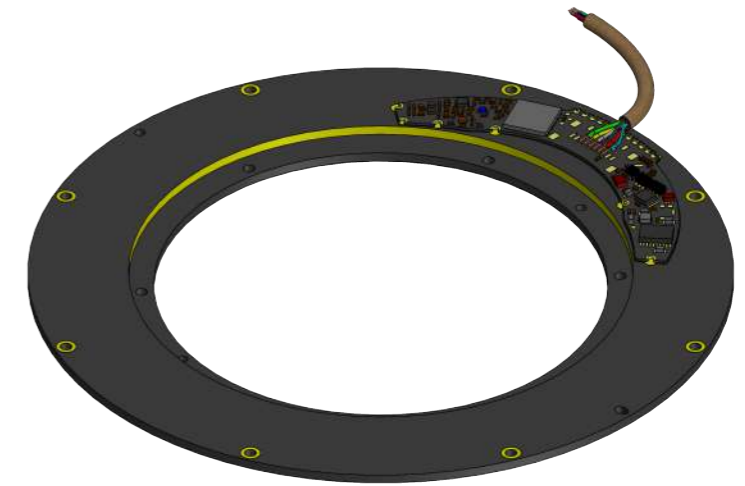

Encoder general view

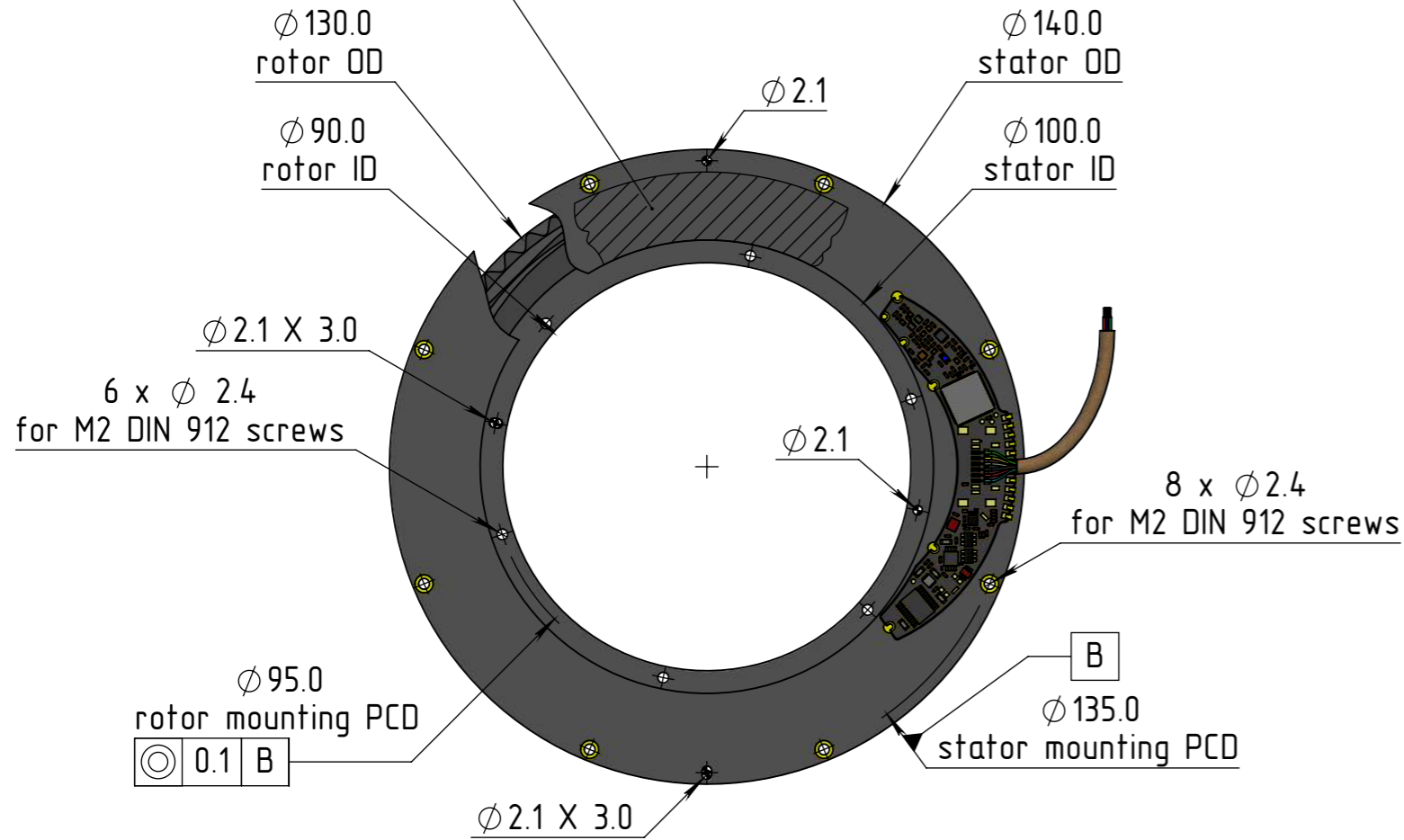
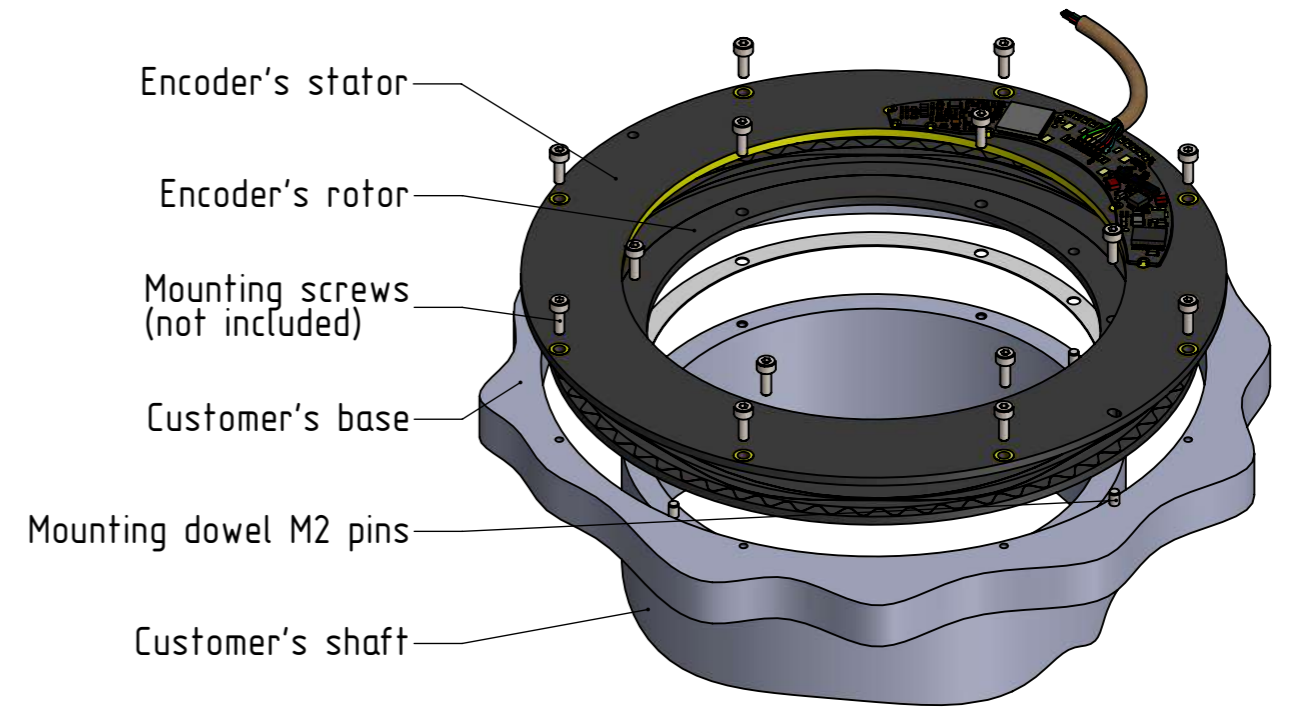

Customer interface, example, exploded view

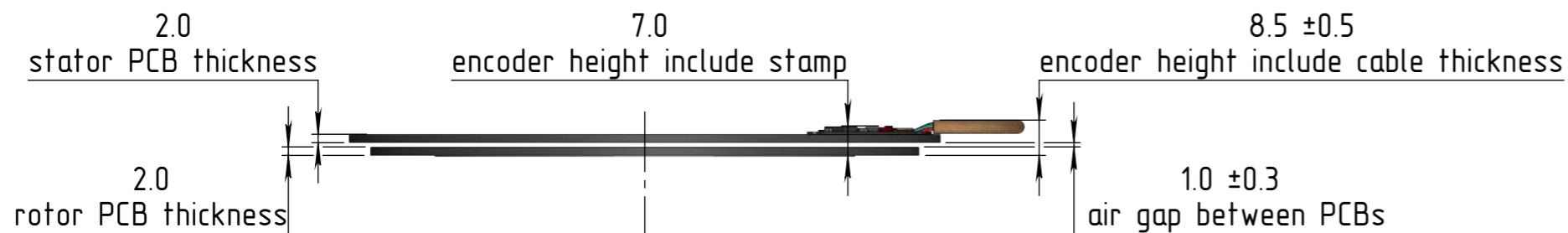

The information contained in this drawing is the sole property of Netzer Precision Position Sensors A.C.S. Ltd. Any reproduction in part or whole without the written permission of Netzer Precision Position Sensors A.C.S. Ltd. is prohibited. The drawing is confidential, and is the property of Netzer Precision Ltd. It must not be disclosed to a third party without written consent of Netzer Precision Ltd.

	NAME	SIGNATURE	DATE		
DRAWN	Michael Agam	MA	18-Jul-2024		
CHK'D					
APPV'D					
UNLESS OTHERWISE SPECIFIED:				TITLE: VLS-140 ICD	
DIMENSIONS ARE IN: mm		SURFACE FINISH: N6		MATERIAL:	
0.5 - 4.9: ±0.05 mm		5 - 30: ±0.1 mm		Coating:	A3
31 - 120: ±0.15 mm		121 - 400: ±0.2 mm		Revision:	
401 - 1000: ±0.3 mm		1001 - 2000: ±0.5 mm		PROJECT:	SHEET 1 OF 1
Between holes: ±0.05 mm		Angles: ±0.5°		CAT NO.: VLS-140 ICD	
On all edges make chamfer 0.1 mm x 45°					