

REVISIONS				
ZONE	REV.	DESCRIPTION	DATE	DRAWN

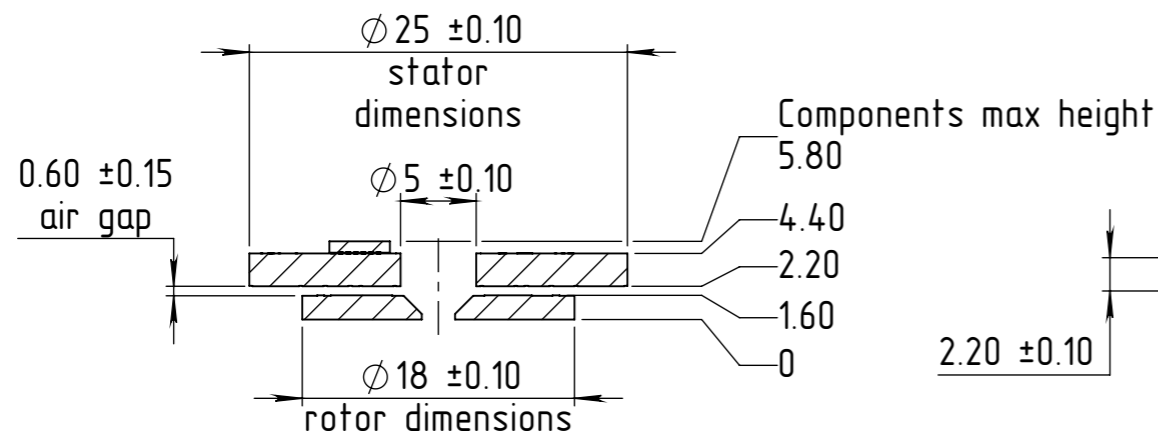

SECTION A-A  
encoder dimensions

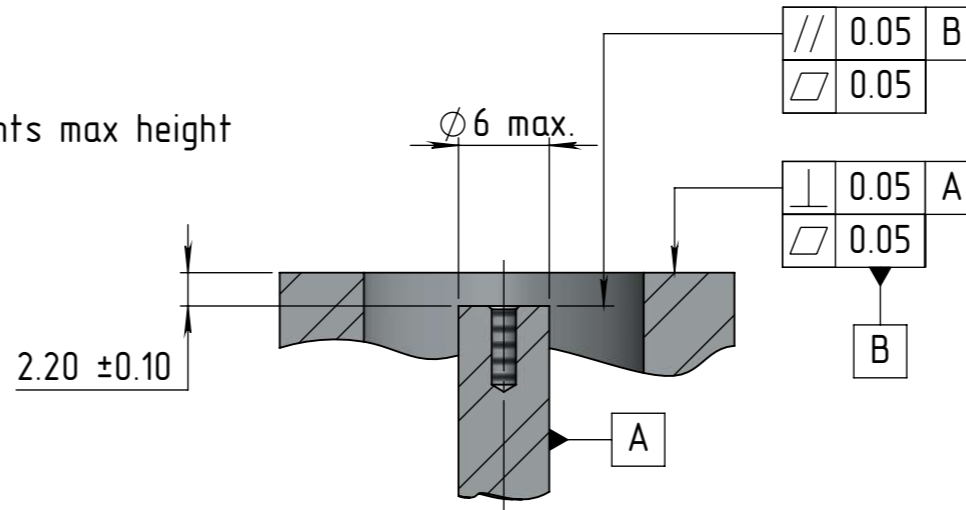

Customer mounting:  
tolerances and requirements

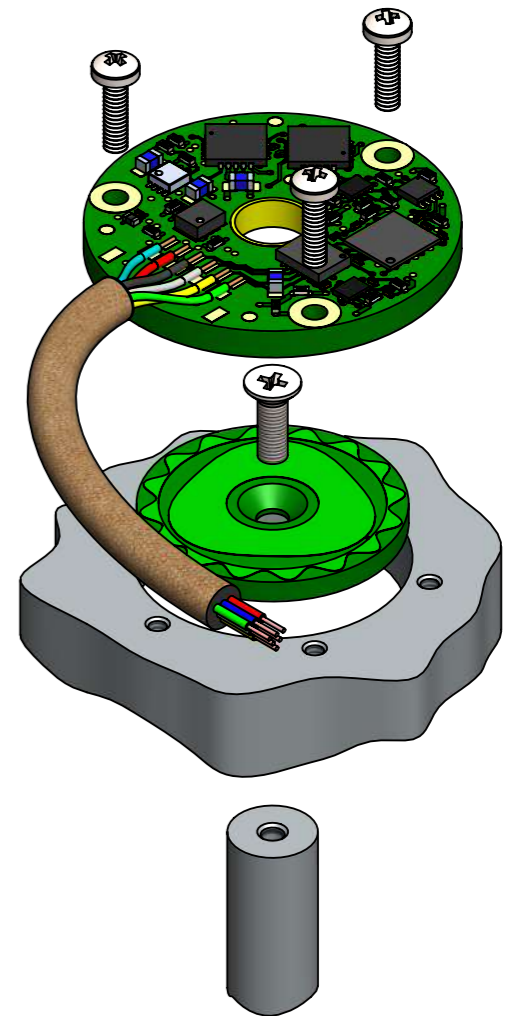

Mounting sample - exploded view

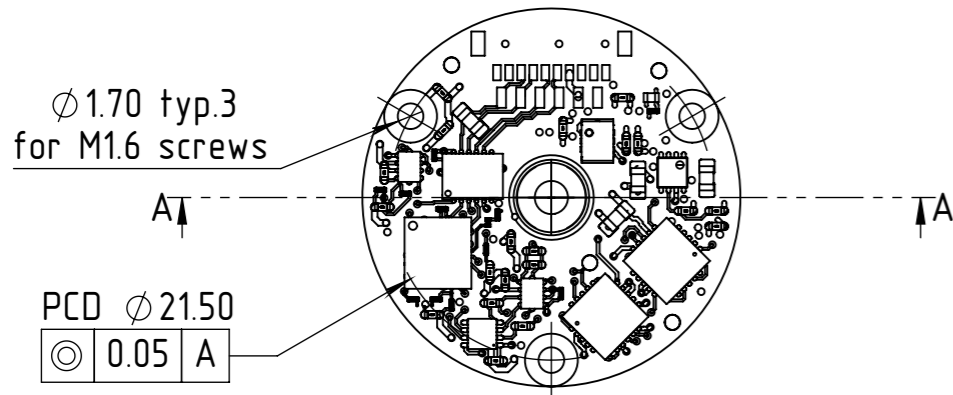

Stator mounting

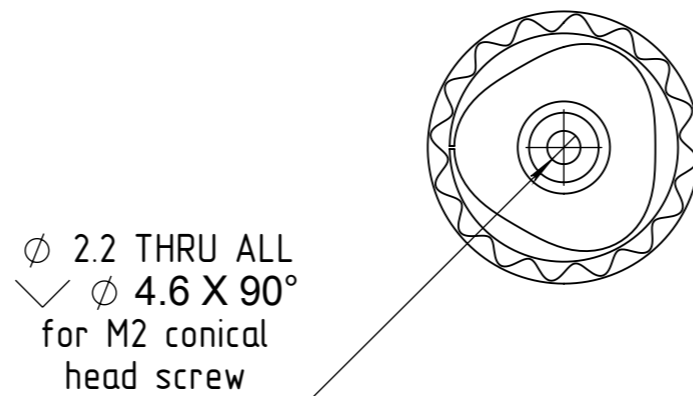

Rotor mounting

Both stator and rotor are positioned  
and centered by screws only

The information contained in this drawing is the sole property of Netzer Precision Motion Sensors Ltd. Any reproduction in part or whole without the written permission of Netzer Precision Motion Sensors Ltd. is prohibited. The drawing is confidential, and is the property of Netzer Precision Ltd. It must not be disclosed to a third party without written consent of Netzer Precision Ltd.

NAME	SIGNATURE	DATE
DRAWN Michael Agam MA		30-Apr-2024
CHK'D		
APPV'D		

**Netzer** Precision Position Sensors A.C.S. Ltd.

UNLESS OTHERWISE SPECIFIED:  
DIMENSIONS ARE IN: mm SURFACE FINISH: N6  
0.5 - 4.9: ±0.05 mm 5 - 30: ±0.1 mm  
31 - 120: ±0.15 mm 121 - 400: ±0.2 mm  
401 - 1000: ±0.3 mm 1001 - 2000: ±0.5 mm  
Between holes: ±0.05 mm Angles: ±0.5°  
On all edges make chamfer 0.1 mm x 45°

TITLE: VLP-25 ICD	SCALE: 2:1
MATERIAL:	Coating:
PROJECT: VLP-25	Revision: 00
CAT NO.: VLP-25 ICD	A3
	SHEET 1 OF 1