

The DL-66 is a member of the DL series of Electric Encoders™ a product line based on Netzer Precision Position Sensor proprietary technology. EE products are characterized by features that enable unparalleled performance:

- High resolution and unparalleled precision
- High tolerance to temperature extremes, shock, EMI, RFI and magnetic fields
- IP65
- Holistic signal generation
- Digital interfaces for absolute position
- Built In Test and diagnostic (BIT)

The holistic structure of the Electric Encoder™ makes it unique: Its output reading is the averaged outcome of the entire area of the rotor. This feature allows the EE a tolerant mechanical mounting and to deliver outstanding precision.

Due to the absence of components such as flexible couplers, glass discs, light sources and detectors along with very low power consumption enables the EE to deliver virtually failure-free performance in nearly all types of conditions.

The internally shielded, DC- operated EE includes an electric field generator, a field receiver, sinusoidal-shaped dielectric rotor, and processing electronics.

The EE output is a digital serial synchronous with absolute position single turn.

This combination of high precision, low profile and, low weight has made Netzer precision encoders highly reliable and particularly well suited to a wide variety of industrial automation and harsh environment applications.

General

Angular resolution	18-20 bit
Maximum tested static error	±0.010°
Extended accuracy static error	±0.005°
Maximum operational speed	4,000 rpm
Measurement range	Single turn, unlimited
Rotation direction	Adjustable CW/CCW*

* Default same direction from bottom side of the encoder

Mechanical

Starting torque	30 x 10 ⁻⁴ N.m
Shaft radial force (max)	100 N
Total weight	350gr
Outer diameter / Profile	71 / 29 mm
Material (case, shaft)	Aluminum / Stainless steel

Electrical

Supply voltage	5VDC ± 5% (Optional 24 VDC)
Current consumption	90 mA
Interconnection	Shielded cable

Environmental

EMC	IEC 6100-6-2, IEC 6100-6-4
Operating temperature range	-40°C to +85°C
Storage temperature	-50°C to +100°C
Relative humidity	98% Non condensing
Shock endurance	150 g for 11 ms
Vibration endurance	20 g 10 – 2000 Hz
Protection	IP 65





Digital SSI Interface

Synchronous Serial Interface (SSI) is a point to point serial interface standard between a master (e.g. controller) and a slave (e.g. sensor) for digital data transmission.

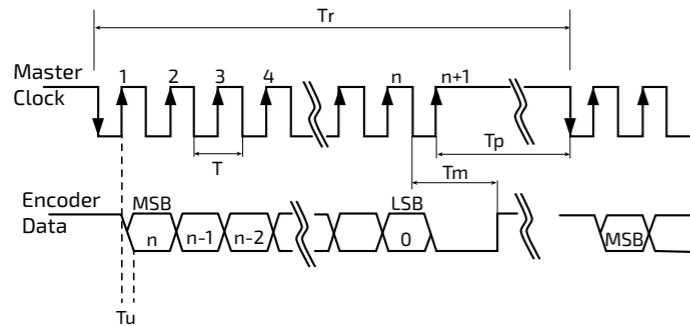

SSI / BiSS output signal parameters

Output code	Binary
Serial output	Differential RS-422
Clock	Differential RS-422
Clock frequency	0.1 ÷ 5.0 MHz
Position update rate	35 kHz (Optional - up to 375 kHz)

SSI / BiSS interface wires color code

Clock +	Grey	Clock
Clock -	Blue	
Data -	Yellow	Data
Data +	Green	
GND	Black	Ground
+5V	Red	Power supply

	Description	Recommendations
n	Total number of data bits	12 - 22
T	Clock period	
f= 1/T	Clock frequency	0.1 ÷ 5.0 MHz
Tu	Bit update time	200 nsec
Tp	Pause time	26 - ∞ µsec
Tm	Monoflop time	>25 µsec
Tr	Time between 2 adjacent requests	Tr > n*T+26 µsec
fr=1/Tr	Data request frequency	

Software tools: (SSI / BiSS - C)

Advanced calibration and monitoring options are available by using the factory supplied [Electric Encoder Explorer software](#). This facilitates proper mechanical mounting, offsets calibration and advanced signal monitoring.

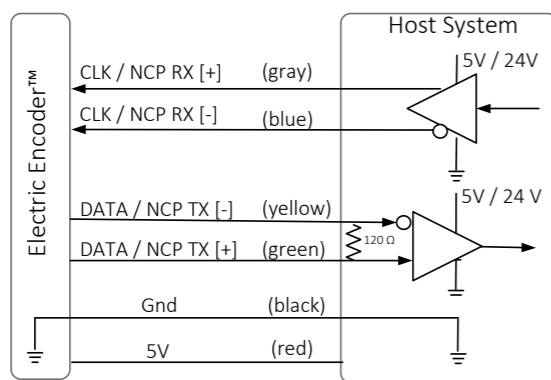

Digital BiSS-C Interface

BiSS - C Interface is unidirectional serial synchronous protocol for digital data transmission where the Encoder acts as "slave" transmits data according to "Master" clock. The BiSS protocol is designed in B mode and C mode (continuous mode). The BiSS-C interface as the SSI is based on RS-422 standards.

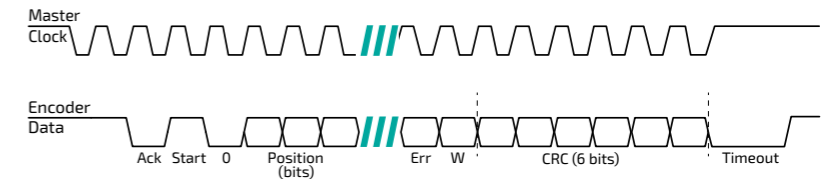

Bit #		Description	Default	Length
28	Ack	Period during which the encoder calculates the absolute position, one clock cycle	0	1/clock
27	Start	Encoder signal for "start" data transmit	1	1 bit
26	"0"	"start" bit follower	0	1 bit
8...25	AP	Absolute Position encoder data		
7	Error	Error (amplitude levels)	1	1 bit
6	Warn.	Warning (non active)	1	1 bit
0...5	CRC	The CRC polynomial for position, error and warning data is: $x^6 + x^1 + x^0$. It is transmitted MSB first and inverted. The start bit and "0" bit are omitted from the CRC calculation.		6 bits
	Timeout	Elapse between the sequential "start" request cycle's.		25 µs

Ordering Code

DL - 66 - S G - S 0 - n n n

DL Product line

Outer Diameter

Output

S	SSi
I	BiSS

Resolution

Code	Bit	CPR
G	18	131,072
H	19	524,288
I	20	1,048,576

BIT (Build In Test): optional

[]	None
B	BIT

EA Extended Accuracy

nnn Custom

Interconnection

0	250mm Flying leads (default)
1	500mm Flying leads
2	750mm Flying leads
3	1000mm Flying leads
[]	None (for connection option)

S Shielded cable 250 mm

C Connector (D38999)

Cable Information

Cable: 30 AWG twisted pair(3):2 (30 AWG 25/44 finned copper, 0.15 PFE to $\varnothing 0.6 \pm 0.05$ OD).

Temperature rating: -60 to +150 Deg C.

Braided shield: Thinned copper braided 95% min. coverage.

Jacket: 0.45silicon rubber jacket $\varnothing 3.45 \pm 0.2$ OD

Pair#	Color
1	Red / Black
2	Gray / Blue
3	Green / Yellow

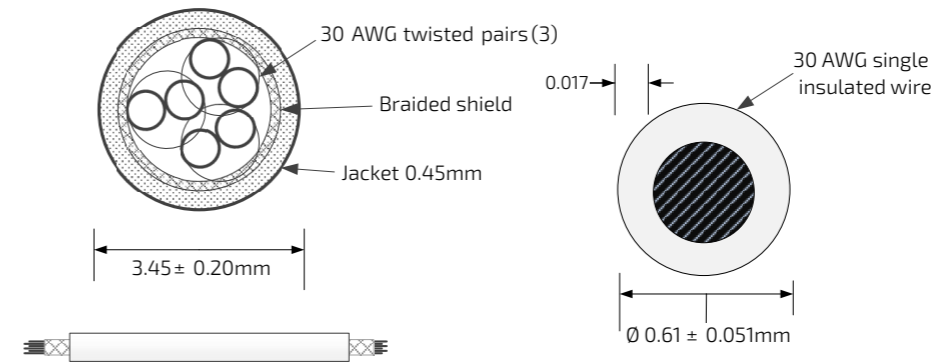

Cable

Connector

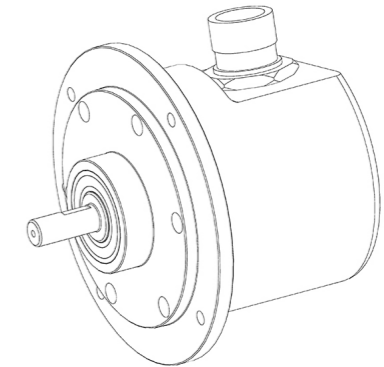
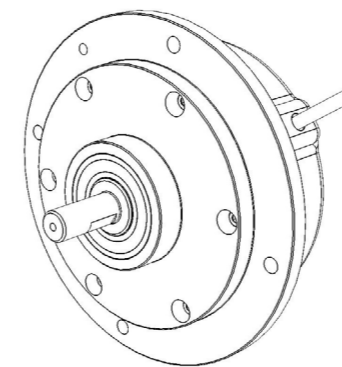

Pin # Description

1	Clock +
2	Clock -
4	Data -
3	Data +
5	GND
6	+5 / 24 VDC



Connector : Amphenol D38999 / 24WB35PB

ICD - Interconnection: Cable

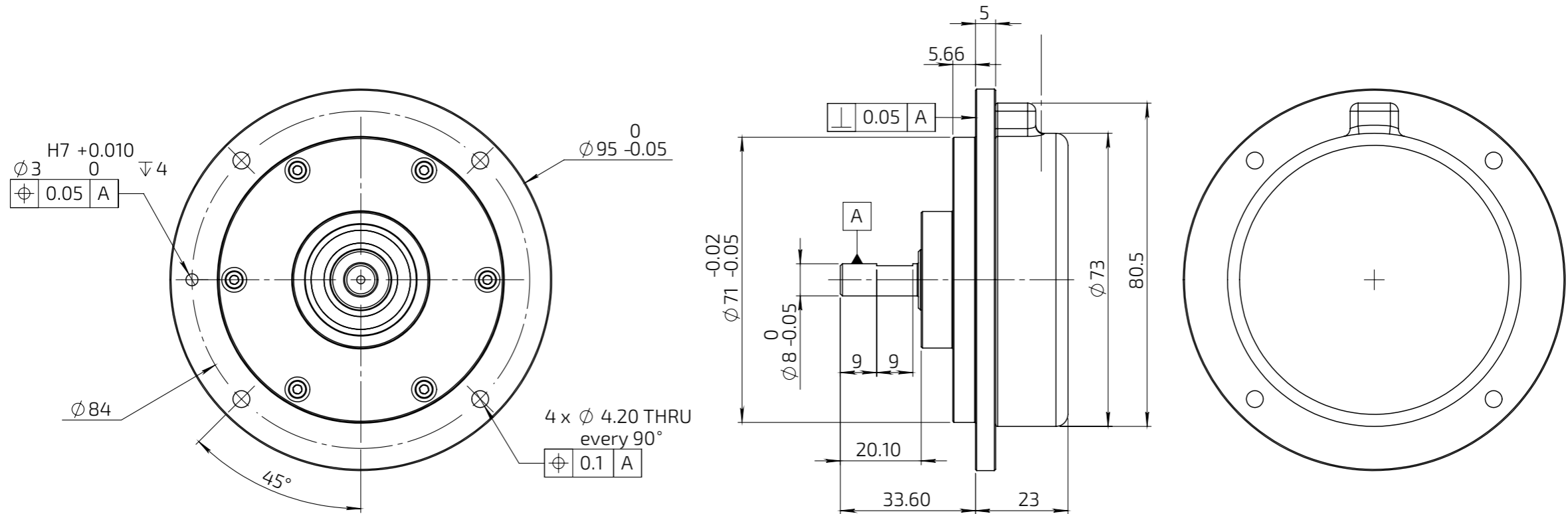

Unless Otherwise Specified

Dimensions are in: mm Surface finish: N6

Linear tolerances

0.5-4.9: ±0.05 mm 5-30: ±0.1 mm

31-120: ±0.15 mm 121-400: ±0.2 mm

ICD - Interconnection: Connector

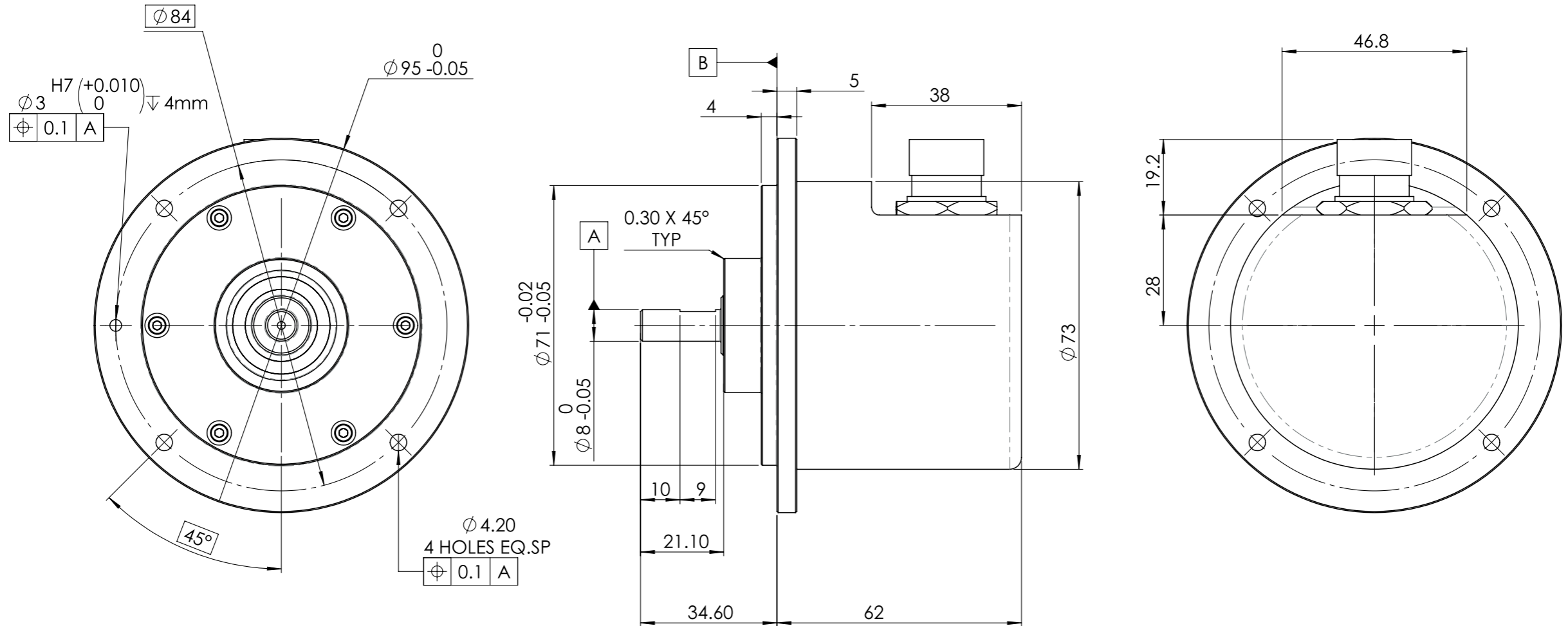

Unless Otherwise Specified

Dimensions are in: mm	Surface finish: N6
Linear tolerances	
0.5-4.9: ± 0.05 mm	5-30: ± 0.1 mm
31-120: ± 0.15 mm	121-400: ± 0.2 mm